

**LINE TERMINALS - WIRE CAPACITY AND QUANTITY** <sup>1</sup>

MAXIMUM MOTOR HORSEPOWER				WIRE SIZE PER PHASE (75°C Cu)	TIGHTENING TORQUE (in-lb)
200-208	220-240	380-415	440-480		
30	40	60	75	(1)#14-#3/0 AWG	50
75	75	125	150	(1)#4-#350 kcmil AWG	180
100	100	150	200	(1)#250-#500 kcmil AWG	550
125	125	200	250	(2)#3/0-#250 kcmil AWG	375
150	150	250	300	(2)#3/0-#350 kcmil AWG	275
-	200	300	400	(2)#400-#500 kcmil AWG	375
250	250	400	500	(3)#3/0-#400 kcmil AWG	375
-	-	500	-	(4)#4/0-#500 kcmil AWG	375

**MOTOR TERMINALS - WIRE CAPACITY AND QUANTITY** <sup>1</sup>

MAXIMUM MOTOR HORSEPOWER				WIRE SIZE PER PHASE (75°C Cu)	TIGHTENING TORQUE (in-lb)
200-208	220-240	380-415	440-480		
20	25	40	50	(1)#8-#2 AWG	54
50	50	75	100	(1)#8-#2/0 AWG	108
100	125	150	250	(1)#6-#300 kcmil AWG	110
200	250	350	500	(2)#4-#350 kcmil AWG	375
250	-	500	-	(2)#2/0-#500 kcmil AWG	400

**WIRE SIZE** <sup>2</sup>  
**SERVICE ENTRANCE GROUND LUG**

wire size	torque (in-lb)
(2)#6-#350 kcmil AWG	
#6-#4	110
#3-#1	150
#1/0-#2/0	180
#3/0-#4/0	250
#250-#350 kcmil	325

**NOTES**

- Incoming line terminals are provided to accommodate wire sizes at 125% of motor full load current per NFPA 20 and NFPA 70. Copper (Cu) wire is required.
- Controller is phase rotation sensitive. Incoming lines L1, L2 and L3 must be in ABC, right hand rotation sequence for proper operation of the phase monitor.
- Motor connections shown are typical. Since motor connections vary widely, refer to the motor manufacturer's connection diagram for specific wiring arrangement.

<sup>1</sup> For correct field wire sizing, refer to the National Electrical Code, NFPA-70.  
<sup>2</sup> When required by the authority having jurisdiction.

**PRESSURE SYSTEM CONNECTION** 1/4" NPT  
**NOTE:** CONTACTS RATED FOR PILOT DUTY ONLY 240 VAC, 8A MAXIMUM LOAD. EXTERNAL CONTROL WIRE #14 AWG MINIMUM RECOMMENDED.

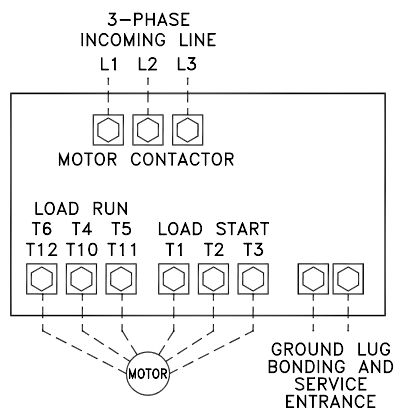

**CONTROL AND ALARM TERMINAL BLOCKS**

- CONTACTS SHOWN IN NO POWER CONDITION, PUMP OFF.
- FOR FIRE PUMP CONTROLLER SCHEMATIC DIAGRAM, SEE DWG. NO. 28DS0011.

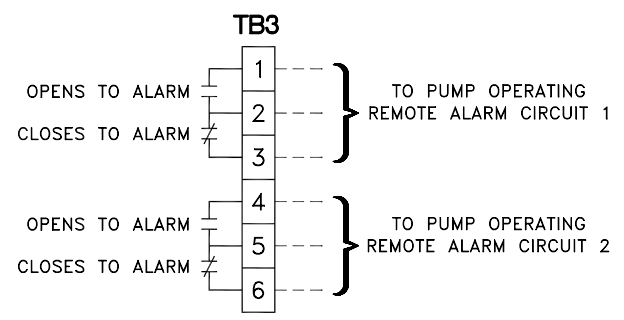
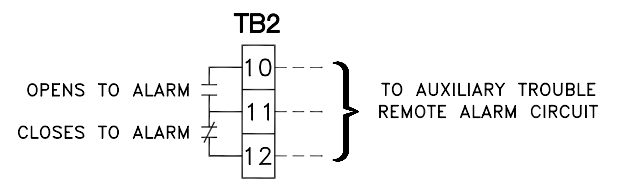
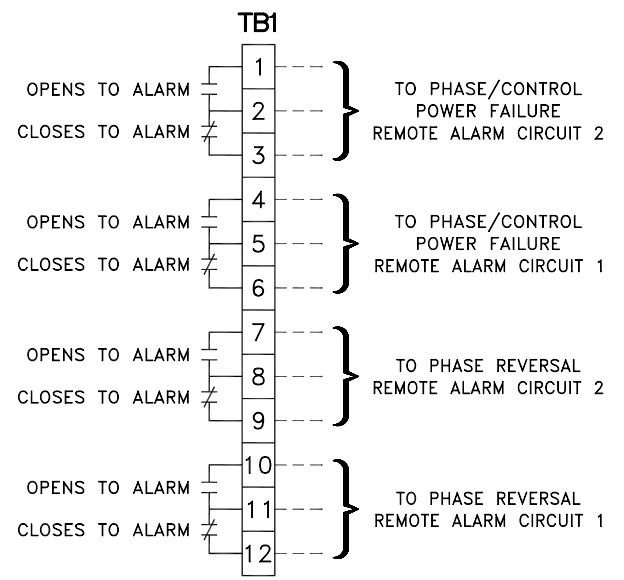
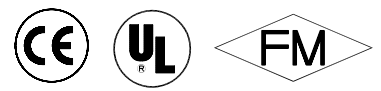
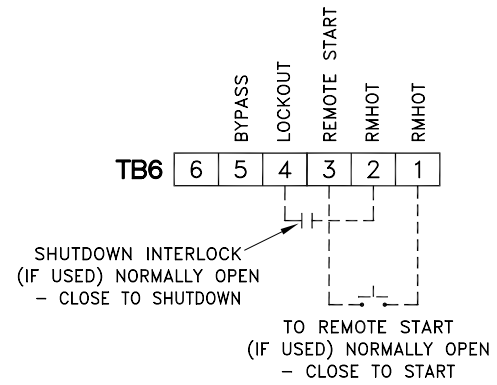

E			M/L NO.	STANDARD LXi-2800 FIELD CONNECTIONS			
D			MOTION:	WYE-DELTA CLOSED TRANSITION STARTER			
C			REF.	FULL SERVICE FPC/ATS COMBO			
B			CADD NO. 28DF0011	DATE 12/04/03	DR. TR	CK.DAMA	APPR.
A	03/06/08	DAMA	UPDATED VALUES IN LINE AND MOTOR TERMINAL TABLES.	Hubbell Industrial Controls, Inc. 4301 Cheyenne Drive, Archdale, N.C. 27263		DRG. NO. 1 OF 1	
Rev.	DATE	BY	DESCRIPTION	A-28DF0011			